

Forged Steel Floating Ball Valve



Technical Specification

- Design Standard : API 608
- Face to Face : ASME B 16.10
- Flanged Size : ASME B 16.5
- Test & Inspection : API598

Notes

The sizes of serial valve connecting Flange and butt-welding terminal can be designed according to customer's requirement

Parts and Material List

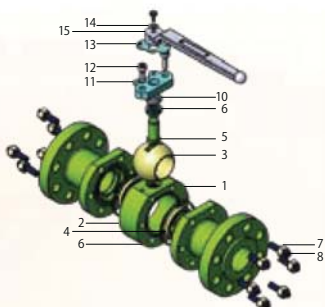

No	Accessory Name	Material
		ASTM
1	Body	A105
2	Bonnet	A105
3	Ball	A105+ENP
4	Seat	PTFE
5	Stem	A182-F6a
6	Gasket	Graphite+Stainless Steel
7	Nut	A194-2H
8	Stud	A193-B7

No	Accessory Name	Material
		ASTM
9	Gasket	PTFE
10	Packing	Graphite
11	Gland	A216-WCB
12	Bolt	A193-B7
13	Indicator	Carbon Steel
14	Ring	AISI 1566
15	Lever	Stainless Steel

- Notes**
- **Ball** : The Material of this part about the anti-sulphur type valve is ASTM(A182-304+Ni.P)
 - **Stem** : The material of this part about the anti-sulphur type valve is ASTM(A276-321) Major parts of the valve series and materials of sealing surface differ according to actual working condition and customer's special requirement.

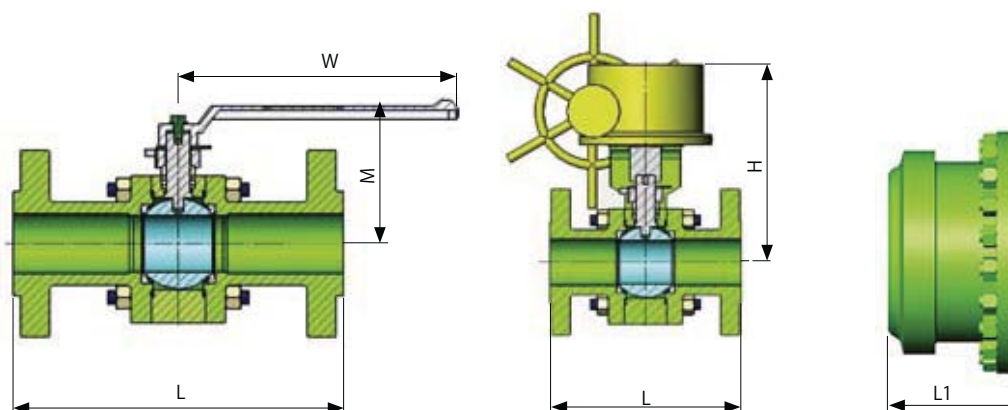

Dimensions and Weights

**PN1.6MPa
CLASS 150**

DN	mm	15	20	25	40	50	65	80	100	125	150	200
NPS	in	½	¾	1	1½	2	2½	3	4	5	6	8
Flange	L	108	117	127	165	178	190	203	229	356	394	457
Butt Welding	L1	140	152	165	190	216	241	282	305	381	403	419
Hand-Operated	H	73	78	86	102	130	142	191	200	226	242	285
	W	130	130	160	180	230	400	400	460	750	750	900
	Kg	3.0	4.0	6.0	12.0	15.0	19.0	22.0	46.0	65.0	85.0	127.0
Worm Gear Operated	H										260	300
	W										400	600
	Type										A	B
	Kg										110	175

**PN2.5 4.0MPa
CLASS 300**

DN	mm	15	20	25	40	50	65	80	100	125	150	200
NPS	in	½	¾	1	1½	2	2½	3	4	5	6	8
Flange	L	140	152	165	190	216	241	282	305	381	403	502
Butt Welding	L1	140	152	165	190	216	241	282	305	381	403	502
Hand-Operated	H	73	80	86	102	136	164	191	223	240	253	307
	W	140	140	180	230	240	400	400	750	750	900	1000
	Kg	4.0	6.0	6.8	11.2	18.3	32.0	38.0	78.0	85.0	102.0	125.0
Worm Gear Operated	H										325	387
	W										400	600
	Type										A	B
	Kg										148	196

**10MPa
CLASS 600**

DN	mm	15	20	25	40	50	65	80	100	125	150	200
NPS	in	½	¾	1	1½	2	2½	3	4	5	6	8
Flange	L	165	190	216	241	292	330	356	406 (432)			
Butt Welding	L1	165	190	216	241	292	330	356	406 (432)			
Hand-Operated	H	73	80	86	110	142	171	185	220			
	W	160	160	230	400	400	650	650	800			
	Kg	4.5	6.2	7.5	12.5	26.1	38.0	44.0	65.0			
Worm Gear Operated	H							182	217			
	W							280	400			
	Type							O	A			
	Kg							50	95			